

Installation instructions

安装说明书

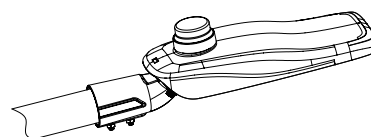

LED street light / LED 路灯

Suitable for use with similar products / 适于用同类产品

Installation Guide / 安全指引

The appliance should be installed, connected and tested by qualified electrician, and in accordance with local regulations. 电器应由合格的电工安装、连接和测试，并符合当地法规。

Turn off the power supply before installation or maintenance of the appliance, and make sure that the cables will not be squeezed or damaged by sharp edges.

在安装或维护设备之前，请关闭电源，并确保电缆不会被锋利的边缘挤压或损坏。

Ensure that LED lighting fixtures do not come into contact with corrosive chemicals, solvents, or abrasive cleaners.

确保 LED 灯具不会接触到腐蚀性化学物质、溶剂或研磨清洁剂等。

To avoid injury or damage to the lighting fixtures, please ensure that the power cord and lighting fixtures are securely installed before connecting the power supply.

为避免受伤或损坏灯具，请在连接电源前确保电源线和灯具安装牢固。

WARNING / 警告

LED lighting fixtures are low voltage distribution. Before connecting the 220V power supply, please ensure that the device is correctly connected to the driver. Otherwise, it will damage the equipment. After activation, hot swapping is not allowed in the drive.

LED 灯具为低压配电。在连接 220V 电源之前，请确保设备已正确连接到驱动器。否则，会损坏设备。开启后，驱动器中不允许热插拔。

Before any maintenance, adjustment, or cleaning of the lighting fixtures, always ensure that the power is turned off and the LED fixtures have cooled down. Electrical appliances can be cleaned with a soft cloth and standard pH neutral detergent.

在对灯具进行任何维护、调整或清洁之前，始终确保电源已关闭，LED 灯具已冷却。可用软布和标准 PH 中性洗涤剂清洁电器。

Electrical appliances should not be covered with insulation blankets or similar materials. Otherwise, it is easy to cause fire accidents.

电器不应被隔热毯或类似材料覆盖。否则易造成火灾故障。

View / 视图

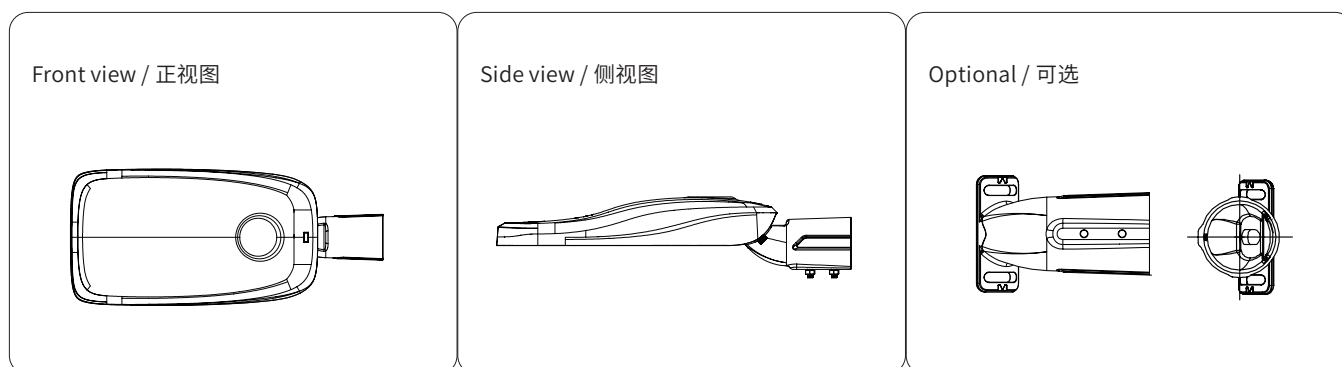

Power connection / 电源连接

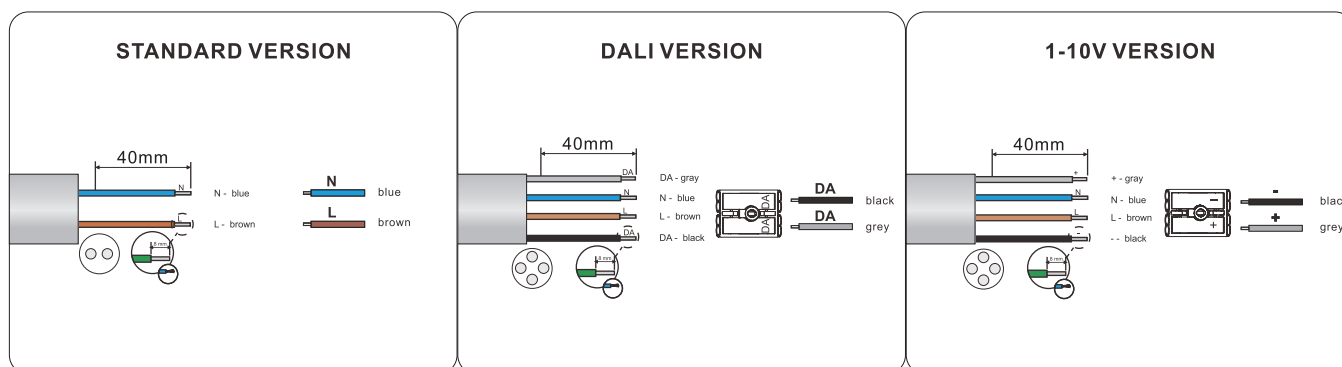

Installation instructions

安装说明书

Suitable for use with similar products / 适于用同类产品

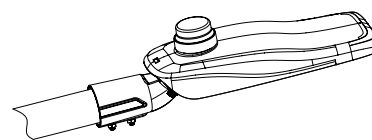

LED street light / LED 路灯

Installation method / 安装方式

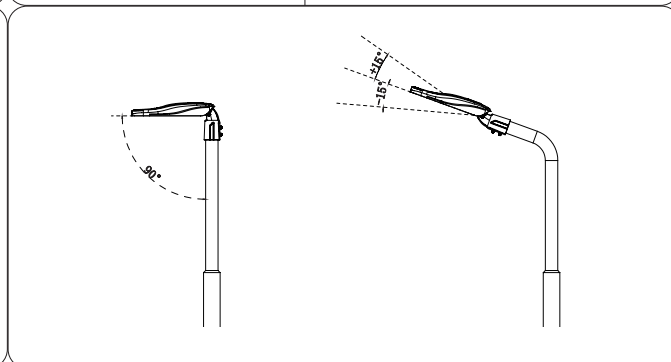
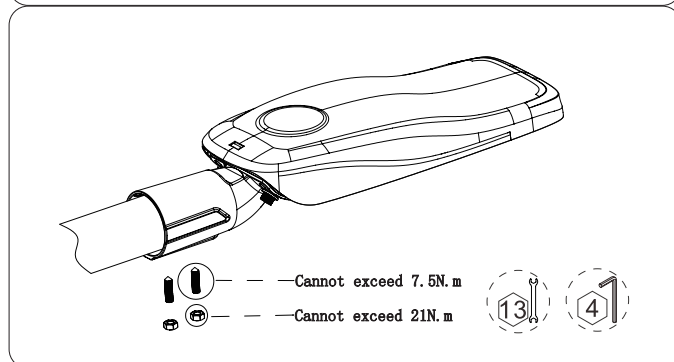
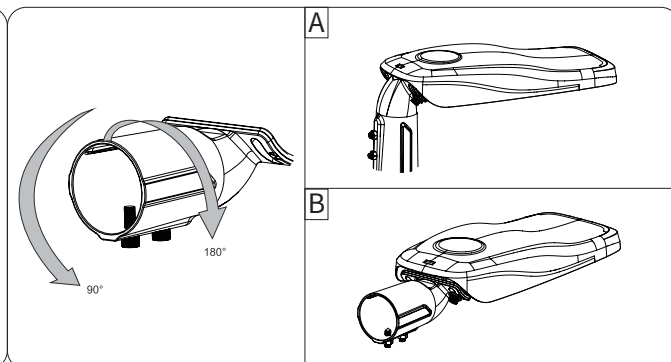
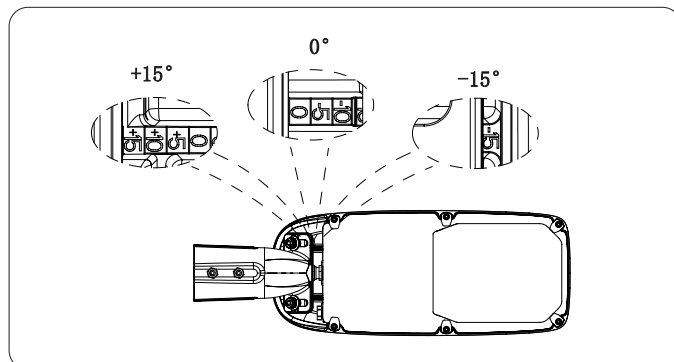

Install sensors / 安装传感器

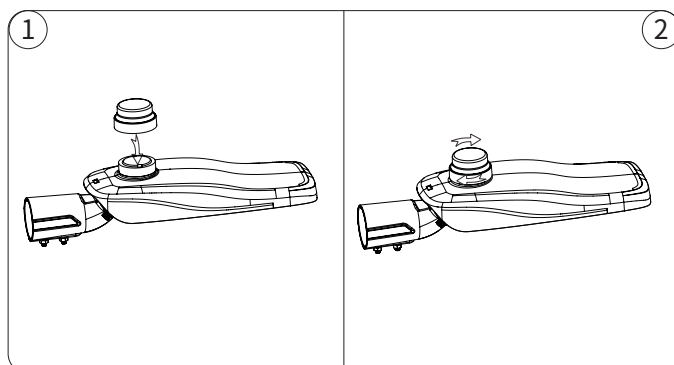

Align the sensor cover with the sensor base in the direction of the arrow, press down, and then tighten clockwise in the direction of the arrow (note: there is an arrow mark on the sensor cover. After tightening, the arrow points in the same direction as the lamp head)

将传感器盖与传感器底座沿箭头方向对齐，按下，然后沿箭头方向顺时针拧紧（注意：传感器盖有一个箭头标记。拧紧后，箭头指向与灯头相同的方向）

Repair and disassembly / 维修拆卸

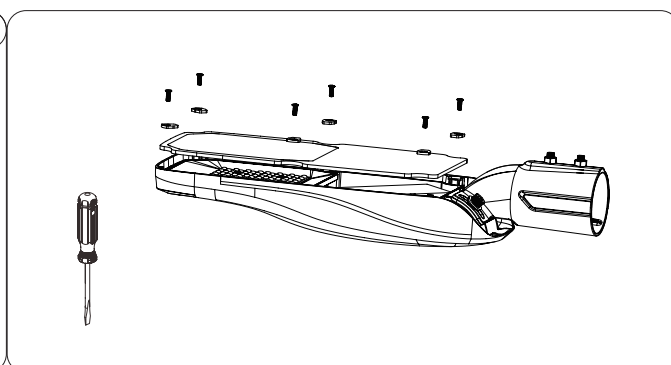

If it is necessary to disassemble and replace the power supply or other components, use a Phillips screwdriver to remove the six screws and glass clip in the order shown in the diagram, then remove the glass and replace the required power supply or components.

如果需要拆卸和更换电源或其他组件，请使用十字螺丝刀按图所示顺序拆下六个螺钉和玻璃夹，然后取出玻璃并更换所需的电源或组件。